

A Cross-Sectional Observational Study of Developmental Coordination Disorders in the School-Age Very Low Birth Weight Children

メタデータ	言語: eng 出版者: 公開日: 2023-02-13 キーワード (Ja): キーワード (En): 作成者: INOUE, Ayumi, HIRASAWA, Kyoko, NAGATA, Satoru メールアドレス: 所属:
URL	http://hdl.handle.net/10470/00033362

A Cross-Sectional Observational Study of Developmental Coordination Disorders in the School-Age Very Low Birth Weight Children

Ayumi Inoue, Kyoko Hirasawa, and Satoru Nagata

Department of Pediatrics, Tokyo Women's Medical University, Tokyo, Japan

(Accepted January 31, 2022)

(Advance Publication by J-STAGE May 17, 2022)

Background: While the prevalence of very low birth weight children (VLBWC) experiencing difficulties as a result of developmental coordination disorder (DCD) is increasing, the diagnostic criteria for DCD have remained unclear.

The objective of this study is to elucidate the current situation and characteristics of DCD in VLBWC.

Method: The VLBWC group ($n = 14$) comprised subjects with a mean birth weight of 986 ± 355 g and a mean gestational age of 26 ± 2.74 weeks. The fine motor skill characteristics of VLBWC were compared to those of the control group using the Movement Assessment Battery for Children—Second Edition (MABC-2). Moreover, the association between the MABC-2 results and the parent-completed child behavior checklists (CBCL) was determined.

Result: There was a relatively high percentage of VLBWC with DCD/DCD risk. A significantly low MABC-2 index reported in VLBWC was attributed primarily to manual dexterity. Moreover, VLBWC with DCD frequently experienced daily difficulties as a result of their incompetence.

Conclusion: The six-year-old VLBWC were more frequently associated with DCD and had more difficulties with clumsiness in their daily lives compared to the control group.

Keywords: very low birth weight infant, developmental coordination disorder, Movement Assessment Battery for Children, child behavior checklist

Introduction

In Japan, the survival rate of neonates, particularly those prematurely born, has increased thanks to global top-class neonatal medicine. Furthermore, the occurrence of prominent neurological sequelae such as cerebral palsy, hearing loss, and visual disturbances, has significantly decreased.¹⁻⁵ However, it has been reported that the prevalence of neurodevelopmental disorders, including devel-

opmental coordination disorder (DCD), is higher in premature infants than in controls.⁶⁻⁸ Indeed, a considerable number of very low birth weight children (VLBWC) and their parents face difficulties in their school lives after entering primary school to deal with their life problems.^{4,7,9-12}

VLBWC are more prone to attention deficit hyperactivity disorder (ADHD)-related problems⁵ so their parents have been concerned about issues such as being warned

Corresponding Author: Kyoko Hirasawa, Department of Pediatrics, Tokyo Women's Medical University, 8-1, Kawada-cho, Shin-juku-ku, Tokyo 162-8666, Japan. hirasawa.kyoko@twmu.ac.jp

doi: 10.24488/twmuj.2021022

Copyright © 2022 Society of Tokyo Women's Medical University. This is an open access article distributed under the terms of Creative Commons Attribution License (CC BY), which permits unrestricted use, distribution, and reproduction in any medium, provided the original source is properly credited.

by their teacher for being disruptive during class and not getting along with their peers.

In general, Japan has scheduled follow-up examinations for VLBW infants and children to evaluate their growth and development at the ages of 18 months, 36 months, six years, and nine years. However, once those children join elementary schools, there are few opportunities to meet them. As a result, we have limited possibility to observe and discuss their developmental concerns with parents, and we are unaware of their actual problems during their school lives. Moreover, their environment from kindergarten to elementary school has changed markedly, making it difficult for VLBWC to adapt. Additionally, we are unable to determine the onset of DCD-related symptoms that would disrupt the daily lives of VLBWC. Therefore, we have been unable to advise them on how to improve their quality of life if they do really have neurodevelopmental disorders. In these instances, we may easily diagnose them as having autism spectrum disorder (ASD) or ADHD, owing to the presence of significant symptoms and clear diagnostic criteria. On the other hand, in the case of children who have DCD-related problems, such as an inability to jump rope or play their recorder during school activities, or who spend an excessive amount of time changing clothes or serving meals, it seems to be much more difficult for these children to be diagnosed as DCD given the limited availability of diagnostic means for this disorder, particularly in Japan.

According to the Diagnostic and Statistical Manual of Mental Disorders, Fifth Edition (DSM-5), DCD is defined as a condition in which a person's fine motor functions are much less competent than the functions expected for their age, and it might interfere with daily activities. We focused on DCD-related symptoms in VLBWC and tried to evaluate these functions by testing single standing, the finger-nose test, tandem gait, and figure description during their previously scheduled follow-up medical checks at aged 6 and 9. We have also tried these evaluations at Tokyo Woman's Medical University Hospital and found that a high percentage of VLBWC have difficulties with those functions, but it is difficult to diagnose as DCD due to a lack of specified criteria for DCD evaluation. To make matters worse, we have few chances to check these children because the visiting rate

following their 6-year medical check has been declining due to their busy school schedules.

Globally, an international standard evaluation battery, the Movement Assessment Battery for Children—Second Edition (MABC-2),¹³ has been used to diagnose DCD. We can quantify manual dexterity, aiming and catching skills, and balance ability using MABC-2. Additionally, in previous studies, VLBWC showed higher rates of DCD symptoms than controls. Furthermore, MABC-2 was used to evaluate VLBWC at ages 8 years,¹⁴ 5-18 years,¹⁵ and 4-5 years,¹⁶ and it was found that the prevalence of DCD was significantly higher than that of controls at all ages. In this study, we aim to examine the Japanese VLBWC for the prevalence of DCD and the types of DCD-related symptoms.

To improve the quality of life of VLBWC, we should focus on DCD-related symptoms and develop effective interventions for those children who have DCD. Thus, the purpose of this study is to elucidate the actual situation and characteristics of DCD in VLBWC using MABC-2, as well as the applicability of MABC-2 to 6-year-old VLBWC.

Subjects and Method

Subjects

There were 73 VLBW babies born at Tokyo Women's Medical University Hospital between January 1st, 2013 and July 31st, 2014, and they were scheduled to turn 6-year-old between January 1st and July 31st, 2019. The following were excluded: Eight infants died during their hospitalization, twelve were referred to and followed up in other hospitals, and four had apparent chromosomal abnormalities or cerebral palsy. We invited 49 infants who reached 6 years old in 2018 and 2019 to our hospital for a medical examination, and 35 of them attended. Finally, we obtained informed consent from 14 of the six-year-old VLBWC families to participate in our study. We scheduled their MABC-2 evaluation and parents' completion of the child behavior checklist (CBCL)¹⁷ following their 6-year-old medical check, including an assessment of their intellectual ability using the Wechsler Intelligence Scale for Children—Fourth Edition (WISC-IV) on the same day of their medical check. We required a

Table 1. Clinical characteristics of the 6-year-old very low birth weight children (VLBWC) group and the control group.

	Number (n)	Age at the MABC-2	Birth weight (g)	Gestational age (weeks)
VLBWC				
boys	7	6.28 ± 0.24	987 ± 355.85	26.6 ± 2.74
girls	7			
Control				
boys	83	6.54 ± 0.73	2,980 ± 102.72	39.6 ± 2.33
girls	74			

control group because there were no standard raw scores or indices available for Japanese children aged 6. To evaluate the characteristics of coordinated movement in VLBWC, we adopted a study design in which we compared the results of MABC-2 between the VLBWC and control group. The control group comprised 161 full-term born and normally developed healthy children, except for those who had already been diagnosed with various neurodevelopmental disorders at a Tokyo suburb kindergarten, with comparable ages and genders to those in the VLBWC group (**Table 1**).

About the guidebook control, it has been based on the data of the normally developed 6 years children in Europe. All participants were informed of the study's aim, and we obtained their informed consent. In the control group, MABC-2 was conducted between April 2018 and July 2020.

Study design

This is a cross-sectional observational study designed to assess the testing time to determine whether children aged 6 are capable of focusing on performing MABC-2 completely and whether it is applicable to children with some intellectual problems. We planned to conduct the whole test and compare the indices of fine motor skills in three MABC-2 areas between VLBWC and control groups. Their parents completed CBCL¹⁷ regarding the problems in their actual life, and we evaluated the relationship between DCD as defined by Henderson's criteria using MABC-2¹³ and the kinds of behavior their parents experienced. In this study, MABC-2 was used to assess the coordinated movement of the subjects (**Figure 1**), with testing completed according to the implementation manual's specifications. This test is divided into three sections, each of which assesses manual dex-

terity, aim and catch skills, and foot balancing ability. Manual dexterity tests assess the ability to post coins, thread beads, and draw a trail. Those for aiming and catching assess the ability to catch and throw beanbags from a distance of 1.8 m onto a target. The balance ability test for feet assesses the ability to stand on one foot, walk in tandem, and jump. The MABC-2 results were compared between the VLBWC and control groups using the mean values of the indices throughout the four evaluation areas. According to the manual instructions, the raw score acquired from each test was converted into 19 points from 1 to 19 using the conversion scale specified for each age group, called assessment points. These assessment points were further converted into another 19-level index using the manual's normalized values. The schema for calculating the assessment points, or indices, is depicted in **Figure 1**. The lower the numerical value of the assessment index in MABC-2, the more difficult it is to perform motor functions. In our study, each individual data point was identified to determine how many percentiles in the raw index's standard distribution curve could be distributed. In general, a child could be identified as having a risk of DCD if his or her index is less than the 15th percentile or as having DCD if it is less than the 5th percentile, according to international criteria.¹³ Thus, in this study, we first compared the distribution of the MABC-2 index in control groups and then determined if we could use the international criteria after confirming the difference between Japanese children and international standard data.

Statistical analysis

We used Student's t-test or Shapiro-Wilk to estimate the difference in MABC-2 results between normally developing Japanese children and controls. All analyses were conducted using SPSS Statistics version 21 for Windows (IBM Corp., Armonk, NY, USA). The difference was considered statistically significant if the p-values were less than 0.05. All p-values of the log-rank test were two-sided.

This study was approved by the Ethics Committee of Tokyo Woman's Medical University with approval number 5004: R2.

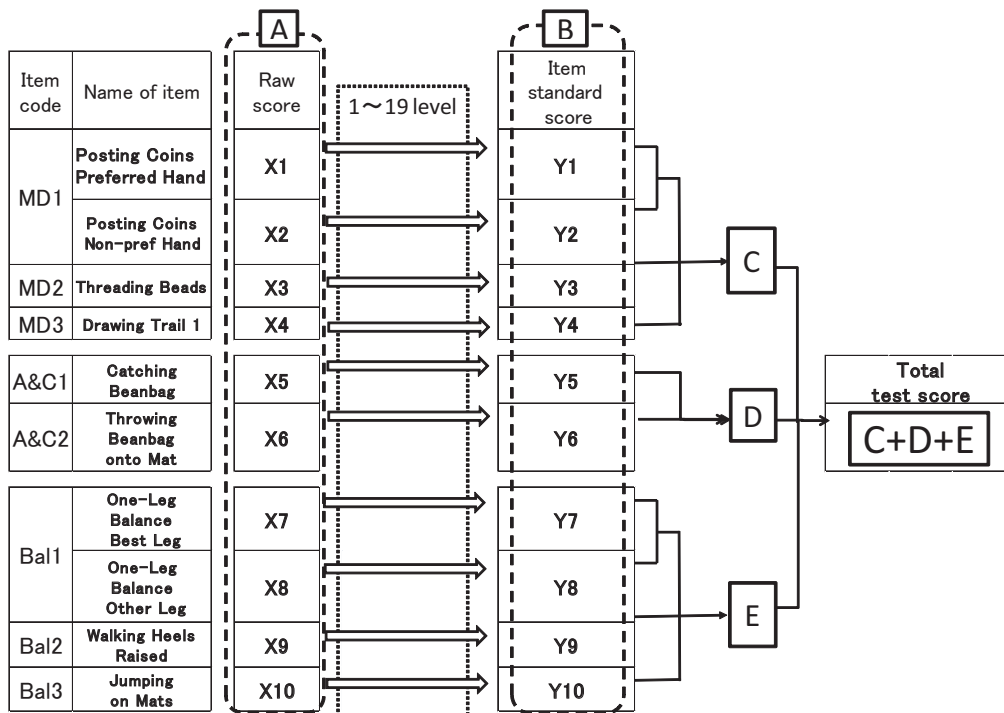

Figure 1. Scoring the motor component of the Movement Assessment Battery for Children—Second Edition (MABC-2).

MABC-2 consists of 11 tests. The raw score (A) acquired from each test is converted into 19 points (B) from 1 to 19, using the conversion scale specified for each age group. The assessment points are further converted into a 19-level index (C, D, and E) using the manual's normalized values.

Reference: reference 13.

Results

Subjects' characteristics and neonatal data (Table 2)

In the VLBWC group, the mean birth weight was 987 ± 355 g and the mean gestational age was 26 ± 2.74 weeks (Table 1). The characteristics of the VLBWC group are described in detail in Table 2. One of the patients had mild grade 1 cerebral palsy, according to the Gross Motor Function Classification System. Cerebral palsy was detected in another case during infancy using magnetic resonance imaging (MRI). Four subjects had slight amblyopia, whereas one had a squint. We evaluated them at an average chronological age of 5 years and 10 months ± 16 days. The total intelligence quotients (IQs) of subjects except one who had not performed that test aged 6 in the VLBWC group ranged from mild disability (<75) to high scores, with one scoring 61, two subjects scoring 75-85, five scoring 85-100, and five scoring 100-125 on the WISC-IV.

MABC-2 evaluation of fine motor function

VLBWC were able to maintain their concentration until the testing time ended. The mean MABC-2 testing time was 22 minutes in the VLBWC group, even among those with an IQ score under 85 on the WISC-IV, compared to 15 minutes in the control group. There were no statistically significant differences in testing times between the two groups.

The distribution of MABC-2 indices in the control group of 6-year-old children in Japan was comparable to a previous study,¹³ and hence we employed the international DCD criteria. The prevalence of DCD to DCD risk as diagnosed by MABC-2 was 28%/50% in the VLBWC group, respectively, compared to 1%/4% in the control group. In the VLBWC group, manual dexterity seems to be significantly impaired compared to the control group (Figure 2A). On the other hand, there were no significant differences in the ability to aim and catch (Figure 2B) or balance (Figure 2C). As a result, the total indices of fine motor skills assessed as assessed by MABC-2 were sig-

Table 2. Demographics data for 6-year-old very low birth weight children.

No	Diagnosis	Gestational age (weeks and days)	Birth weight (g)	MRI at neonatal period	DCD/DCD risk	WISC-IV				
						F	V	PR	W	PS
1		22w4d	490	the trace of the hemorrhage at the subependymal body part of ventricles.	DCD risk	83	97	76	85	83
2	Attention-Deficit Hyperactivity Disorder	24w0d	640	nothing particular	DCD			N.A		
3		24w3d	446	nothing particular		83	88	85	76	96
4		26w2d	802	IVH (right: IV left: III)	DCD	100	109	100	97	91
5		27w2d	999	nothing particular	DCD risk	97	93	93	94	94
6		27w3d	681	nothing particular		91	103	82	94	91
7	Autism	30w0d	1,418	not examined		98	99	91	88	115
8		30w3d	1,238	nothing particular		87	97	78	82	99
9		31w0d	1,118	nothing particular	DCD	104	93	120	97	96
10		31w0d	1,235	IVH hydrocephalus		108	111	104	120	88
11		31w1d	1,195	nothing particular		126	119	132	103	118
12		31w1d	1,463	nothing particular		122	109	139	103	113
13		31w4d	1,493	nothing particular	DCD risk	113	103	115	120	102
14	CP & Intellectual Disability	31w5d	1,496	hemorrhages at the bilateral frontal horn of lateral ventricle	DCD	61	72	67	71	61

CP, cerebral palsy; IVH, intraventricular hemorrhage; DCD, developmental coordination disorder; WISC-IV, Wechsler intelligence scale for children-fourth edition; N.A, not assessed; F, final intelligent quotient; V, verbal comprehension index (VCI); PR, perceptual reasoning index (PRI); W, working memory index (WMI); PS, processing speed index.

nificantly low in VLBWC (**Figure 2D**). And some patients had associating neurodevelopmental disorders, but any significant characteristics had not been found. Considering about the gender differences, the results only about the manual dexterity of MABC-2 in girl VLBWC were significantly superior to those of boys shown as **Table 3**.

The actual problems in terms of daily life activities as assessed by CBCL in the 6-year-old VLWBC were detected to be associated with DCD. The results of CBCL revealed that the item (question 62) regarding the exercise's clumsiness was more frequently answered positively in VLBWC with DCD/DCD risk than in those without DCD/DCD risk (**Figure 3**). More specifically, VLBWC with lower MABC-2 indices had much more difficulties, particularly with manual dexterity-related activities. For instance, parents of these children had raised concerns about VLBWC's inability to play ball games with their peers, write due to weak pen pressure or improper pen handling, or transcript in their classrooms.

Discussion

We concluded that MABC-2 is effective for diagnosing children with DCD even if they have a mild lower or borderline IQ of 60-85 on the WISC-IV and can easily understand and obey the testing instructions. The time required to complete MABC-2 did not differ significantly between the VLBWC and control groups and was not excessively long to maintain adequate concentration on the test. DCD may be significantly more prevalent in the VLBWC group. According to Roberts et al.,¹⁴ the prevalence of DCD/DCD risk children was 5%/8% in the control group, compared to 16%/23% in the VLBWC group for children aged 8 years. Moreover, Edwards et al.¹⁵ verified that the odds ratio for DCD risk in children weighing less than 1,500 g was 6.2 compared to normally developed children aged 5-18 years. Furthermore, Zwicker et al.¹⁶ reported that 40% of 3-year-old children weighing less than 1,250 g were at risk for DCD. In our current study, we found significantly more DCD/DCD risk in the VLBWC group than in previous reports, where subjects' weight ranged between 1,250 g and 1,500 g and subjects were associated with reduced neo-

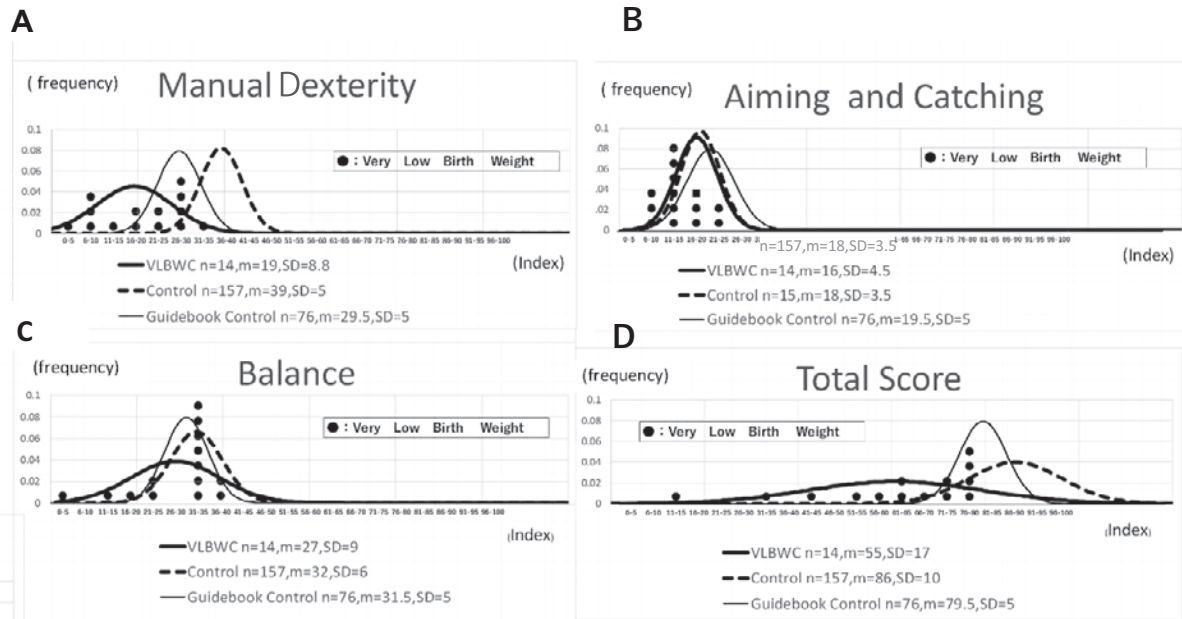

Figure 2. This showed the result of MABC-2. Normal distribution of index for 6-year-old very low birth weight children (VLBWC), controls, and guidebook control. Each dot shows the individual index of MABC-2 in VLBWC subjects.

(A) Manual dexterity index: A significant difference was recognized, in which the 6-year-old VLBWC group took 19 (SD = 8.8) and the control group took 39 (SD = 5) ($p < 0.001$). (B) Aiming and catching index: There were a few differences: 16 (SD = 4.5) for the 6-year-old VLBWC group; and 18 (SD = 3.5) for the control group ($p < 0.080$). (C) Balance index: There were a few differences: 16 (SD = 4.5) for the 6-year-old VLBWC group; and 18 (SD = 3.5) for the control group ($p < 0.061$). (D) Total score index: A significant difference was recognized, in which the 6-year-old VLBWC group took 55 (SD = 17) and the control group took 79 (SD = 5) ($p < 0.001$).

Table 3. The raw score for 6-year-old very low birth weight children (VLBWC) and controls in both girls and boys.

		Manual dexterity	Aiming & catching	Balance	Total score
VLBWC					
boys	mean	12.00	19.00	30.00	60.00
	SD	5.10	4.20	6.30	15.00
girls	mean	22.00	14.00	24.00	59.00
	SD	8.60	4.10	12.00	21.00
Control					
boys	mean	37.79	18.03	31.68	87.50
	SD	5.78	3.67	5.11	10.97
girls	mean	38.94	17.03	31.79	87.76
	SD	5.17	3.33	4.44	7.46

natal brain damage, such as periventricular leukomalacia compared with our study. We speculated that the increased prevalence of DCD in our study compared to previous reports from other countries was attributed to the prematurity or fragility of VLBWC groups. In other words, our VLBWC groups comprised a greater propor-

tion of VLBWC who were delivered prematurely and weighed less at birth, and as a result, their neonatal clinical course appeared to be more critical. Additionally, in our study, we found that VLBWC typically lack manual dexterity, particularly when compared to their ability to aim and catch or balance. Previous research reported only the ratio of DCD/DCD risk children, but not the functional characteristics of fine motor skills that indicated which functions would be most affected.¹⁴⁻¹⁶ At that point, our research appears to be novel. Additionally, in terms of gender differences in fine motor movements, it is generally accepted that girls are superior to boys.^{18,19} Our findings were consistent with those of previous studies shown in **Table 3**. When considering the association between DCD and other developmental disorders, it was found that VLBWC associated with ASD typically experienced DCD-related difficulties. Additionally, VLBWC without an intellectual disability have been associated with DCD symptoms. Moreover, when considering inter-

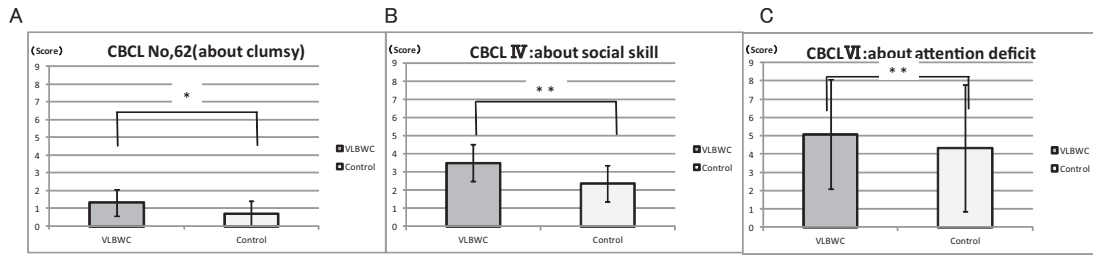

Figure 3. Comparison of the child behavior checklist (CBCL) between 6-year-old very low birth weight children (VLBWC) and the controls.

(A) Checklist no. 62 on the CBCL. (B) Social skill index (IV) on the CBCL. (C) Attention deficit index (VI) on the CBCL.

*indicates > 0.05 , **indicates > 0.01 .

vention for children with DCD, there is a question regarding the clinical course of DCD and how and when DCD affects the actual life of VLBWC. Even in previous research, it was uncertain when the DCD characteristics would have an effect on their lives. The detailed clinical characteristics of children with DCD appear to be critical to improving the daily lives of VLBWC. We would describe the characteristics of the WISC-IV assessed intellectual abilities of 6-year-old VLBWC with DCD/DCD risk. In the VLBWC group, 75% of children with DCD/DCD risk had normal intellectual ability, with an IQ of 85 or higher on the total score. However, when the WISC-IV indices were assessed in detail in DCD/DCD risk children with normal IQ, it was found that some children had significantly low perceptual reasoning and processing speed indices despite having normal working memory and verbal comprehension indices. Children may require coordination of visual and manual handling skills to perform well on the perceptual reasoning and processing speed indices, and so their clumsiness with fine motor skills appears to be one of the reasons for their low index in those areas on the WISC-IV. When 6-year-old children with normal total or verbal complex index are called in for medical examinations, it appears to be somewhat difficult to identify their daily problems due to some inappropriate behaviors probably caused by low perceptual or processing speed indices. Fine coordination movement may require sensory integration of tactile and visual sensations, as well as automation of the senses and motor learning, which can be accelerated through daily exercise and play. In early life, when our visual function and sensory integration are rapidly developing, it is critical for children to have a variety of daily physical exer-

cise experiences that can help them develop these movements by acquiring smoothness for various movements. However, due to their delayed motor development, the VLBWC had few chances for daily physical play, which resulted in a lack of visual automation acquisition. These conditions may contribute to VLBWC's susceptibility to DCD or risk of DCD. Thus, it is necessary to accurately assess the etiology of developmental coordinated movement in addition to understanding the WISC-IV characteristic during the medical examination of VLBWC in order to help physicians guide patients on how to improve their school lives. In previous reports, they hypothesized that the pathogenic lesion of DCD would be located in the occipital and parietal lobes and would affect motor function, vestibular function, or the cerebellum, as well as proprioception (deep sensation) and its related neural pathway.^{20, 21} Visual radiation of VLBWC is well documented to be susceptible to periventricular leukomalacia and to exhibit some visual impairments. It is plausible that these damages may affect visual automation in VLBWC with DCD/DCD risk to some extent. Although the apparent lesion was not detected on MRI during infancy in 14 cases of the VLBWC group in our study, we could not rule out the possibility of minute lesions. As a result, it is possible that VLBWC have less developed fine motor coordination movements. Thus, it is reasonable to assume that more play involving sensory integration and fine motor coordination would improve their fine motor movement skills.

There are a lot of studies in Japan about the neurodevelopment of VLBWC at the ages of 3 and 6 years, but there are few studies about developmental coordinated movement. In this study, we were able to describe some

of the DCD characteristics of VLBWC. They should be evaluated for their visual cognition relating to their movements, as well as the variables that may have affected their development when they were younger. Furthermore, we would like to emphasize the necessity and importance of detecting children with DCD and providing advice on how to improve their school lives. In this study, we were unable to identify the onset of DCD-related difficulties because the subjects in this study had no abnormalities in medical examinations, including the New-edition Kyoto development test, in their daily lives when they were 3 years old. We would like to determine a method for diagnosing children with DCD at the 3-year-old medical check of VLBWC. The limitation of this study is the subject selection. We cannot rule out the possibility of bias due to the fact that VLBWC were typically recruited with strong motives to have medical examinations due to obvious difficulties in their daily lives and hence participated in this study.

Conclusion

Using MABC-2, this study indicated that a high percentage of VLBWC had difficulties with manual dexterity and that the VLBWC group had a high prevalence of DCD/DCD risk. Moreover, VLBWC with DCD/DCD risk had far more difficulties in their daily lives due to the exercise's clumsiness. Thus, it would be necessary to detect any symptoms or daily difficulties with visual cognition that could influence the development of fine movement and attention in VLBWC as early as 3 years old.

Sources of Funding: This research received no specific grant from any funding agency in the public, commercial, or not-for-profit sectors.

Conflicts of Interest: The authors declare that there are no conflicts of interest.

Ethical Approval: This study was approved by the Ethics Committee of Tokyo Woman's Medical University with approval number 5004: R2.

Disclaimer: Kyoko Hirasawa is one of the Associate Editor of Tokyo Women's Medical University Journal on the Journal's Editorial Board. She was not involved in the editorial evaluation or decision to accept this article for publication at all.

References

1. Touyama M, Touyama J, Ochiai Y, et al. Long-term survival of children with cerebral palsy in Okinawa, Japan. *Dev Med Child Neurol.* 2013;55(5):459–63.
2. Inoue H, Ochiai M, Sakai Y, et al. Neurodevelopmental outcomes in infants with birth weight ≤ 500 g at 3 years of age. *Pediatrics.* 2018;142(6):e20174286. doi: 10.1542/peds.2017-4286.
3. Lampi KM, Lehtonen L, Tran PL, et al. Risk of autism spectrum disorders in low birth weight and small for gestational age infants. *J Pediatr.* 2012;161(5):830–6.
4. Joseph RM, Korzeniewski SJ, Allred EN, et al. Extremely low gestational age and very low birthweight for gestational age are risk factors for autism spectrum disorder in a large cohort study of 10-year-old children born at 23-27 weeks' gestation. *Am J Obstet Gynecol.* 2017; 216(3):304.e1–304.e16.
5. Shum D, Neulinger K, O'Callaghan M, et al. Attentional problems in children born very preterm or with extremely low birth weight at 7-9 years. *Arch Clin Neuropsychol.* 2008;23(1):103–12.
6. Johnson S, Strauss V, Gilmore C, et al. Learning disabilities among extremely preterm children without neurosensory impairment: Comorbidity, neuropsychological profiles and scholastic outcomes. *Early Hum Dev.* 2016; 103:69–75.
7. Bolk J, Farooqi A, Hafström M, et al. Developmental coordination disorder and its association with developmental comorbidities at 6.5 years in apparently healthy children born extremely preterm. *JAMA Pediatr.* 2018;172 (8):765–74.
8. Janssen AJWM, Oostendorp RAB, Akkermans RP, et al. High variability of individual longitudinal motor performance over five years in very preterm infants. *Res Dev Disabil.* 2016;59:306–17.
9. Saigal S, den Ouden L, Wolke D, et al. School-age outcomes in children who were extremely low birth weight from four international population-based cohorts. *Pediatrics.* 2003;112(4):943–50.
10. Hutchinson EA, De Luca CR, Doyle LW, et al. School-age outcomes of extremely preterm or extremely low birth weight children. *Pediatrics.* 2013;131(4):e1053–61.
11. Anderson PJ, Doyle LW, Victorian Infant Collaborative Study Group. Executive functioning in school-aged children who were born very preterm or with extremely low birth weight in the 1990s. *Pediatrics.* 2004;114(1):50–7.
12. Aarnoudse-Moens CSH, Weisglas-Kuperus N, Duivenvoorden HJ, et al. Executive function and IQ predict mathematical and attention problems in very preterm children. *PLoS One.* 2013;8(2):e55994.
13. Henderson SE, Sugden DA, Barnett A. Movement assessment battery for children-second edition (Movement ABC-2). London (Great Britain): Pearson; 2007. Appendix A–B; p. 161–74.
14. Roberts G, Anderson PJ, Davis N, et al. Developmental coordination disorder in geographic cohorts of 8-year-old children born extremely preterm or extremely low birthweight in the 1990s. *Dev Med Child Neurol.* 2011; 53(1):55–60.

15. Edwards J, Berube M, Erlandson K, et al. Developmental coordination disorder in school-aged children born very preterm and/or at very low birth weight: a systematic review. *J Dev Behav Pediatr.* 2011;32(9):678–87.
 16. Zwicker JG, Yoon SW, Mackay M, et al. Perinatal and neonatal predictors of developmental coordination disorder in very low birthweight children. *Arch Dis Child.* 2013;98(2):118–22.
 17. Achenbach TM, Ruffle TM. The child behavior checklist and related forms for assessing behavioral/emotional problems and competencies. *Pediatr Rev.* 2000;21(8):265–71.
 18. Cole WR, Mostofsky SH, Larson JCG, et al. Age-related changes in motor subtle signs among girls and boys with ADHD. *Neurology.* 2008;71(19):1514–20.
 19. Dirlikov B, Rosch KS, Crocetti D, et al. Distinct frontal lobe morphology in girls and boys with ADHD. *Neuroimage Clin.* 2014;7:222–9.
 20. Sripada K, Løhaugen GC, Eikenes L, et al. Visual-motor deficits relate to altered gray and white matter in young adults born preterm with very low birth weight. *Neuroimage.* 2015;109:493–504.
 21. van Houdt CA, Oosterlaan J, van Wassenae-Leemhuis AG, et al. Executive function deficits in children born preterm or at low birthweight: a meta-analysis. *Dev Med Child Neurol.* 2019;61(9):1015–24.
-